

Approved	Checked	Designed	DEVELOPMENT SPECIFICATION	P/N:LNJ818C8SRA1	TEMPORARY
		T. Tabata			

T Y P E	Soft Orange Light Emitting Diode					
A P P L I C A T I O N	Indicators					
M A T E R I A L	GaAsP					
O U T L I N E	Attached					
A B S O L U T E M A X I M U M R A T I N G S	P	+1 I <sub>FP</sub>	I <sub>FDC</sub>	V <sub>R</sub>	Topr	Tstg
	60	60	20	3	-30~+85	-40~+100
	mW	mA	mA	V	°C	°C
C O N D I T I O N	Ta=25±3°C					

Test Specification

I t e m	Symbol	C o n d i t i o n	Typ	Limit		Unit
				Min	Max	
Forward Voltage	V <sub>F</sub>	I <sub>F</sub> =10mA	1.93		2.6	V
Reverse Leakage Current	I <sub>R</sub>	V <sub>R</sub> = 3V			10	μA
Luminous Intensity #2	I <sub>O</sub>	I <sub>F</sub> =10mA DC	2.5	1.3		mcd
Peak Emission Wavelength	λ <sub>p</sub>	I <sub>F</sub> =10mA DC	610			nm
Spectral Line Half Width	Δλ	I <sub>F</sub> =10mA DC	40			nm

- #1. The Condition of I<sub>FP</sub> is duty 10 % , Pulse width 1 ms
- #2. Tolerance of luminous intensity: ±20%.

- NOTE
- ★1. Please contact the Panasonic local office if you design at low current (below 1mA DC) or pulse current operation and have any questions.
  - ★2. Soldering conditions.....Refer to Handling note.
  - ★3. Compositions of the lead ..... Cu/Ni/Au plating
  - ★4. Circuit to operate LED.

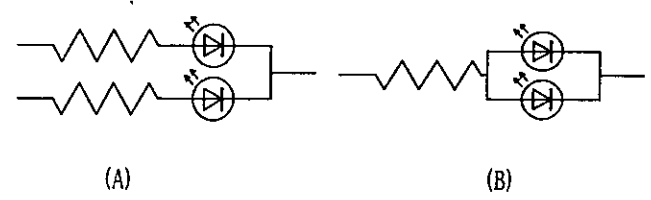

(A) Recommended circuit.  
 (B) The difference of brightness between the LED could be found due to the V<sub>F</sub> characteristics of each LED.

Oct. 24. 2001			
---------------	--	--	--

Approved	Checked	Designed
		T. Takata

DEVELOPMENT SPECIFICATION

P/N:LNJ818C8SRA1

TEMPORARY

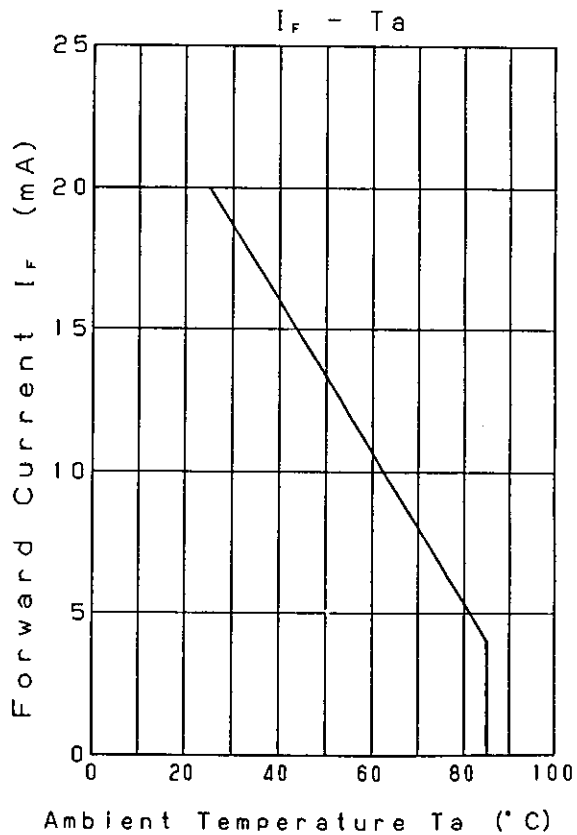
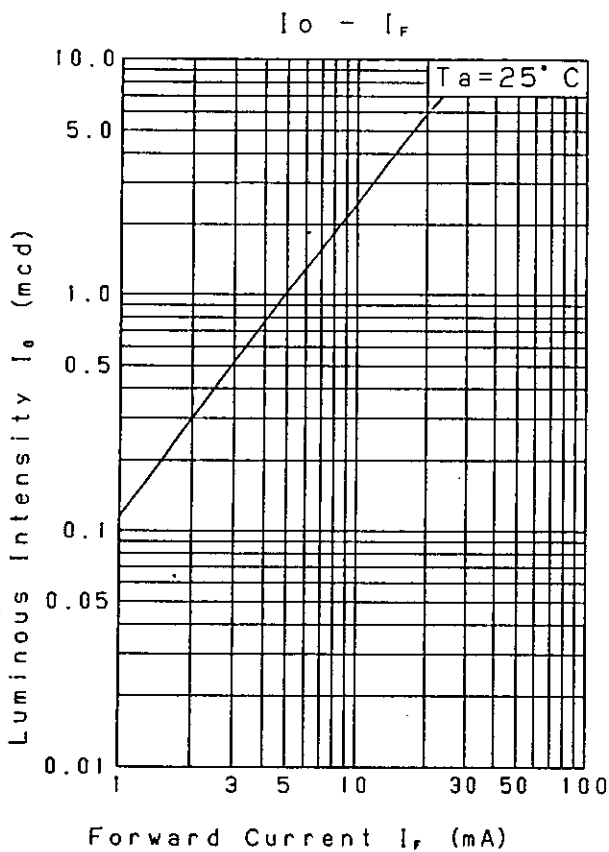
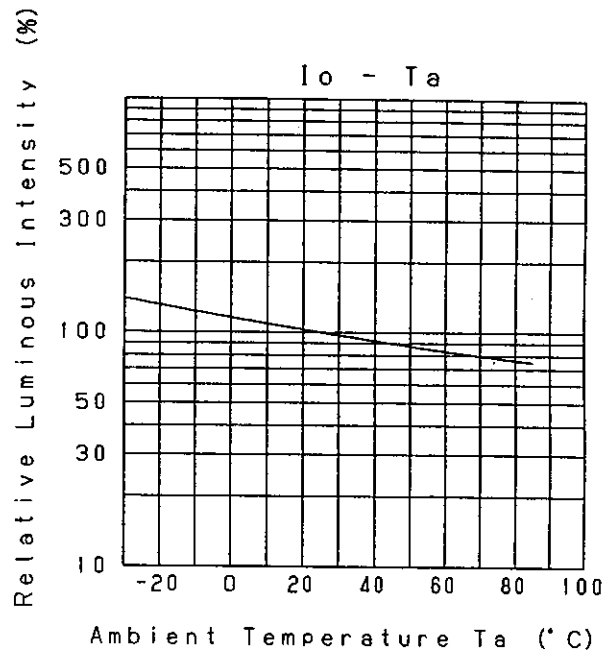
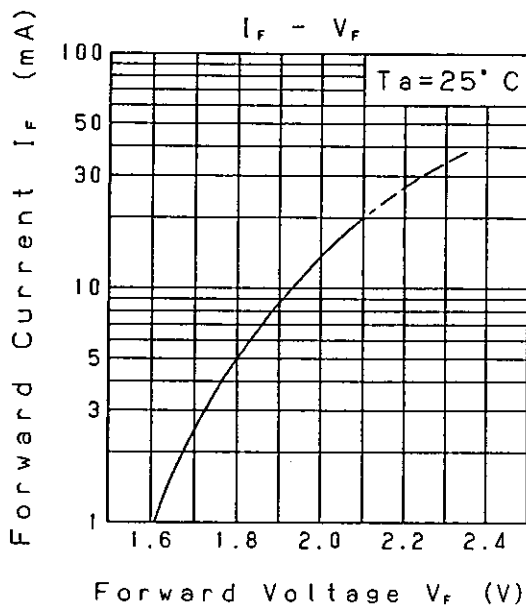

Nov. 7. 2001

Approved	Checked	Designed
		T. Takata

DEVELOPMENT SPECIFICATION

P/N:LNJ818C8SRA1

TEMPORARY

Relative Luminous Intensity  
Wavelength Characteristics

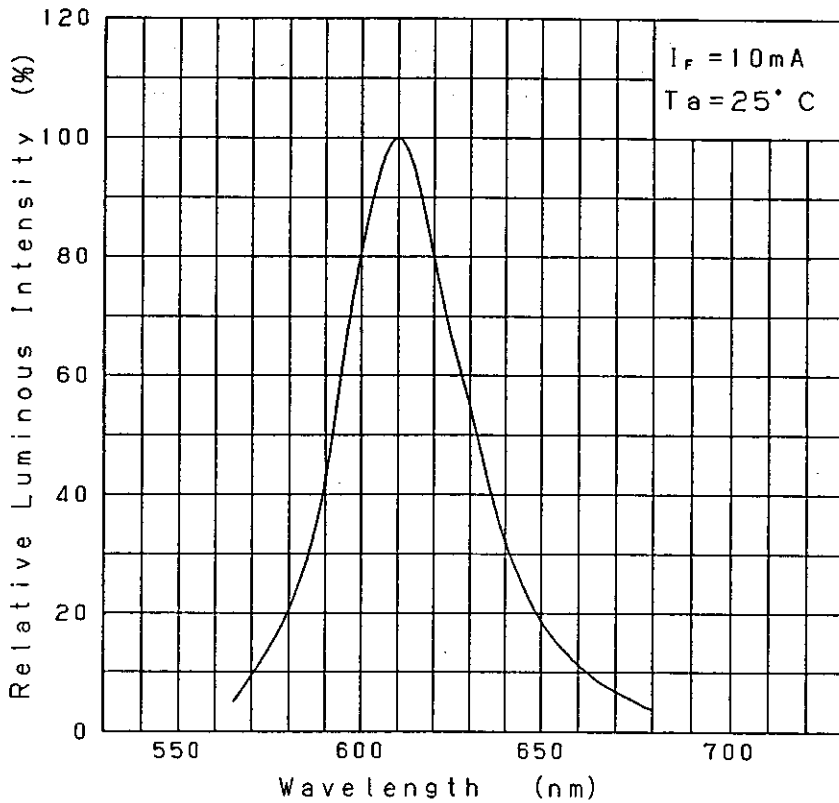

Directive Characteristics

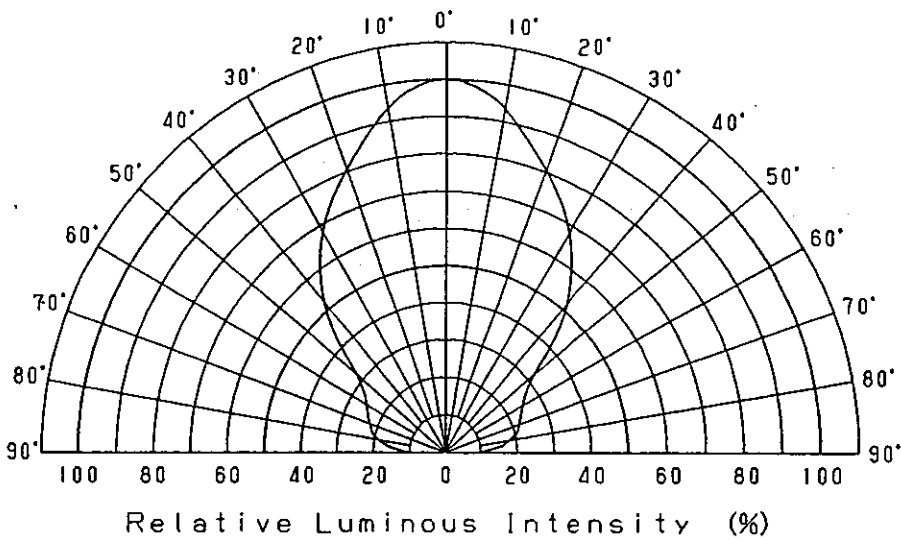

Nov. 7. 2001

Approved	Checked	Designed	DEVELOPMENT SPECIFICATION (OUTLINE)	TEMPORARY
		T. Tabata		

Outline

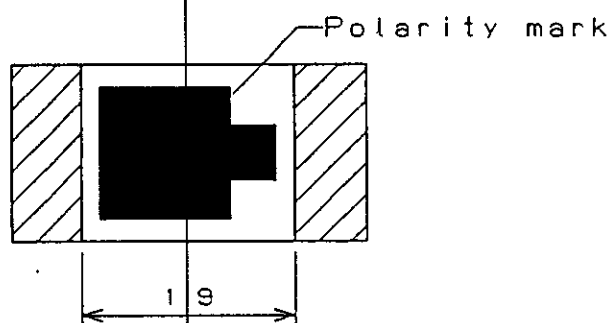
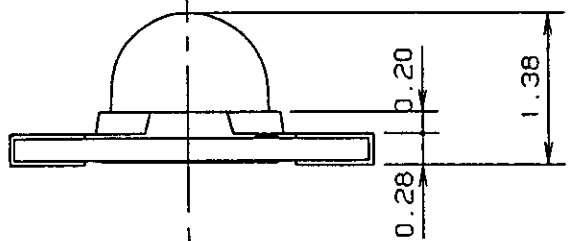
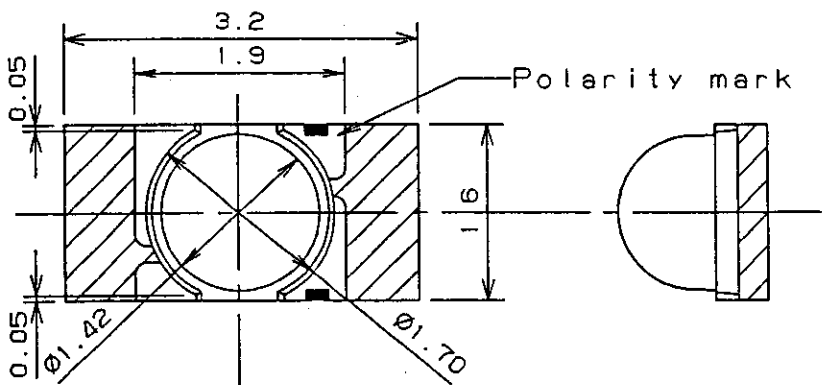

Recommended Land Layout

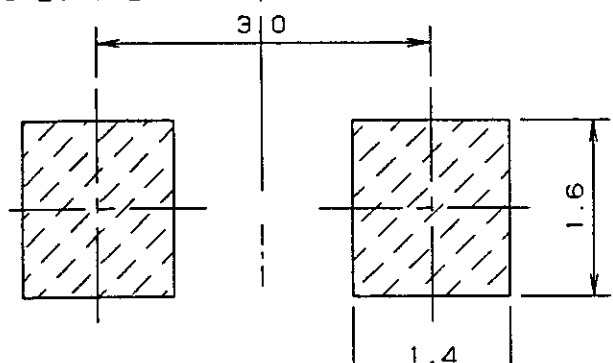

Polarity

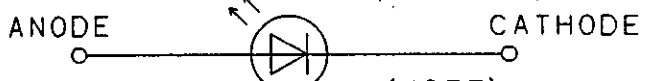

- (NOTE)
1. Unit: mm
  2. Tolerance unless specified is  $\pm 0.15$ .
  3. indicate Au terminal.

Nov. 7. 2001			
--------------	--	--	--